

4

3

2

1

- A) Electrical Requirements 480/3/60 VAC 50 Amp Service  
(45kVA step-up transformer required when only 208/240 service available-  
**NOT INCLUDED WITH MACHINE**)  
CAT5 network connection  
Laser Only: Separate 120 VAC 15 Amp waterproof receptacle  
**(Do not use receptacle inside the main electrical enclosure)**  
Network switch with a minimum of 5 ports.

- B) Machine operation  
Air Requirements 110 psi 35 cfm clean, dry air  
1 - 1/2" industrial interchange nipple

Part Flotation

- Air Requirements 110 psi 10 cfm air  
1 - 1/2" industrial interchange nipple

- C) Water Requirements 40 psi 15 gpm  
1 - GH fitting for halo (Fresh or gray water filtered to 50 micron)  
1 - GH fitting for through spindle (Fresh or gray water filtered to 25 micron only)

- D) Pump prime and make up water (Must be fresh water or strained with 50 mesh)  
1 - 3/4" NPTF connection

- E) Waste water collection  
2 - 2" NPTF connections  
(Tanks can be oriented to drain left or right of the machine)

- F) Vacuum pump overflow  
1 - 1" NPTF connections

Refer to Sheet 2 for all service locations.

**Unloading and Placement**

Lift the machine base from the bottom using a forklift with 8' long forks and a minimum lift capacity of 30,000 lbs. Install the supplied leveling feet before setting the machine base on the floor. (Not higher than 3 1/2" from floor to machine base.

The operating location of the machine should have 6" thick reinforced concrete floor. If possible, set the machine base on a single slab with no joints or structural cracks. The machine base, control cabinet and vacuum pump should be placed at least 3' from walls or other obstructions to eliminate pinch points. **Do NOT put machine directly against a wall or obstacle.** Take care not to block any building exits. Avoid placing the machine in high traffic areas. Also, make sure that the selected location is well lit.

Once in place, rough level the machine base making sure that all of the leveling feet are touching the floor. It is desirable to have the machine base as low as possible to the floor.

Locate the machine control cabinet at front left of the machine base. Connect the flexible conduit on the machine base to the control cabinet. Note: If your machine was special ordered with a right hand cabinet, All "A)" connections will be on the opposite side of the machine.

Please contact Northwood (502) 267-5504 if you have any questions regarding the machine placement or service requirements.

# ISO View

Service Legend  
Unloading and  
Placement instructions

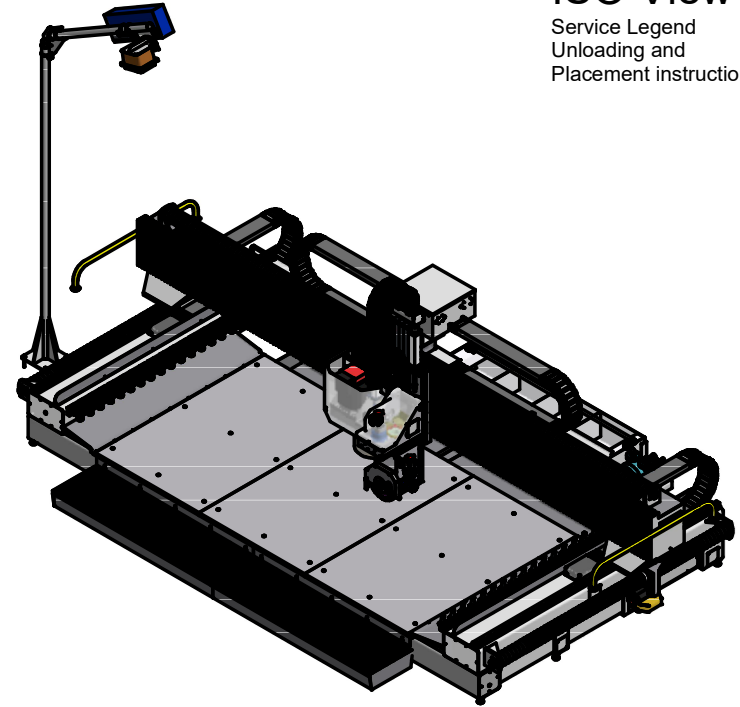
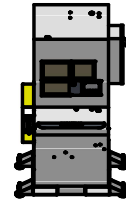

A

A

 <b>Northwood</b> Machine Manufacturing Company <i>"Integrated Solutions. Real Results"</i>			
			TITLE:
SIZE:	PART NUMBER:	REV:	
	<b>SW158GE-FC-MITER-SMSB</b>	<b>A</b>	
DATE:	DRAWN:	Ines	SHEET 1 OF 6
3/12/2007			

4

3

2

1

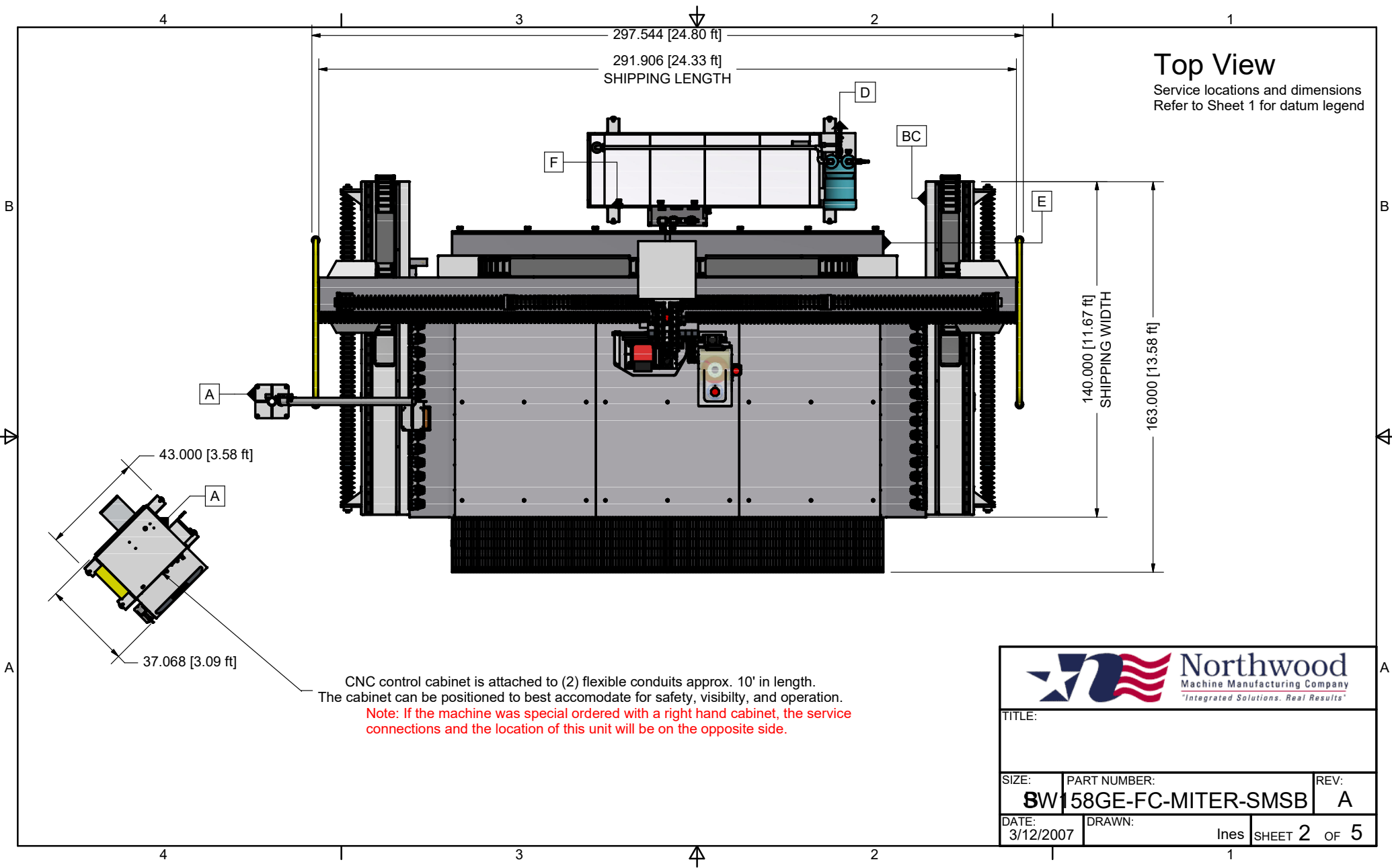

**Top View**  
 Service locations and dimensions  
 Refer to Sheet 1 for datum legend

CNC control cabinet is attached to (2) flexible conduits approx. 10' in length.  
 The cabinet can be positioned to best accommodate for safety, visibility, and operation.  
**Note: If the machine was special ordered with a right hand cabinet, the service connections and the location of this unit will be on the opposite side.**

 <b>Northwood</b> Machine Manufacturing Company <i>"Integrated Solutions. Real Results"</i>		
TITLE:		
SIZE:	PART NUMBER:	REV:
	<b>SW158GE-FC-MITER-SMSB</b>	<b>A</b>
DATE:	DRAWN:	Ines SHEET 2 OF 5
3/12/2007		

# Front View

Dimensions

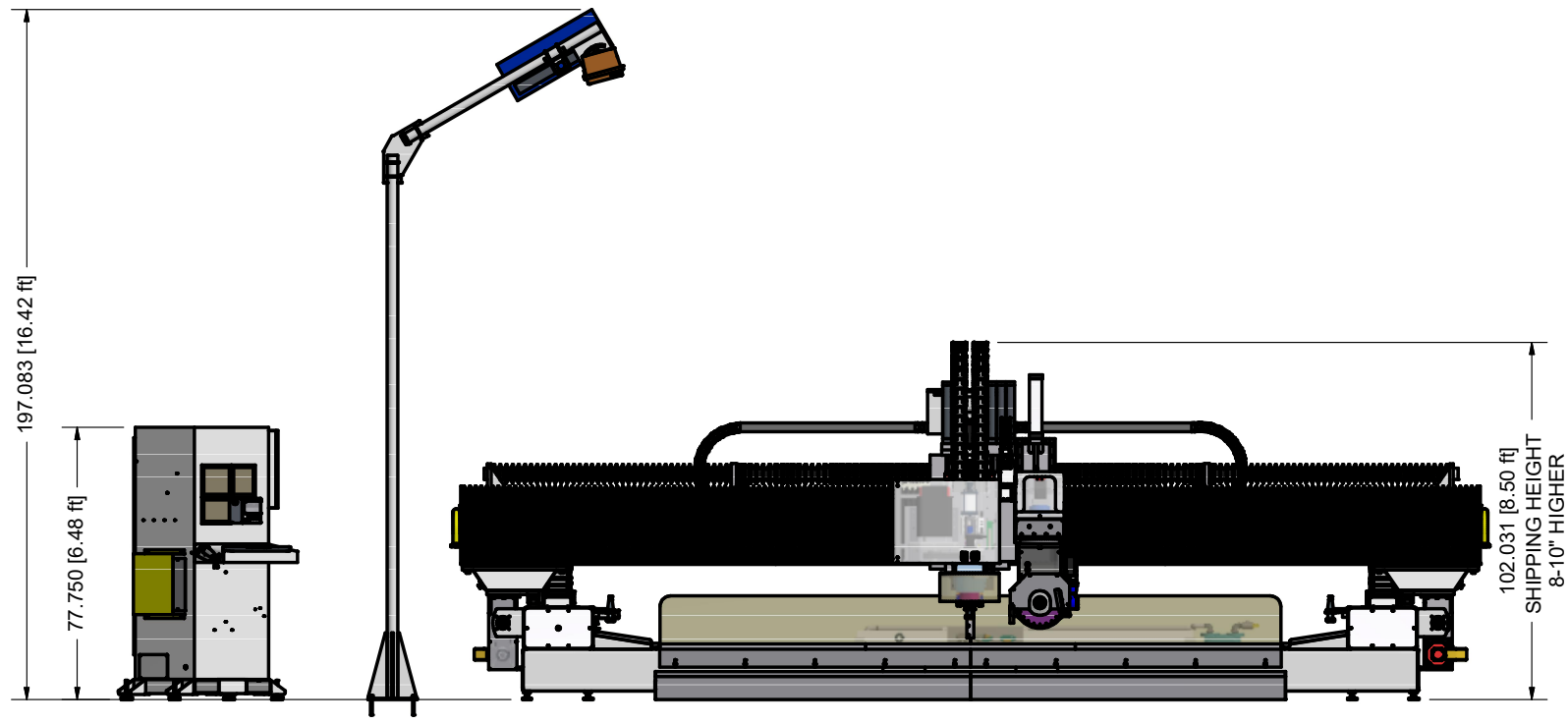



 <b>Northwood</b> Machine Manufacturing Company <i>"Integrated Solutions. Real Results"</i>		
TITLE:		
SIZE:	PART NUMBER:	REV:
	<b>SW158GE-FC-MITER-SMSB</b>	<b>A</b>
DATE:	DRAWN:	Ines SHEET 3 OF 5
3/12/2007		

Side View

Left Side

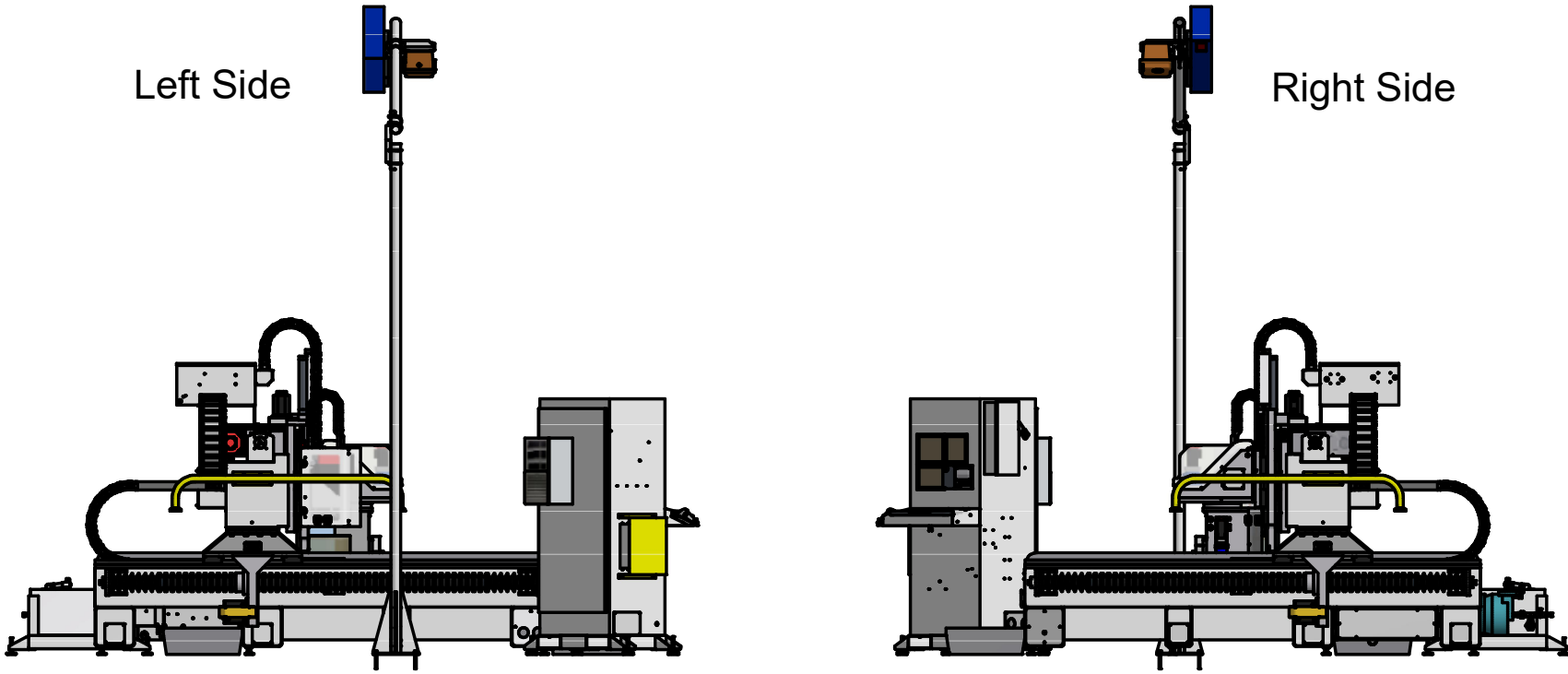
Right Side



		
TITLE:		
SIZE:	PART NUMBER:	REV:
	<b>SW158GE-FC-MITER-SMSB</b>	<b>A</b>
DATE:	DRAWN:	Ines SHEET 4 OF 5
3/12/2007		

# Bottom View

Leveling Pad Layout

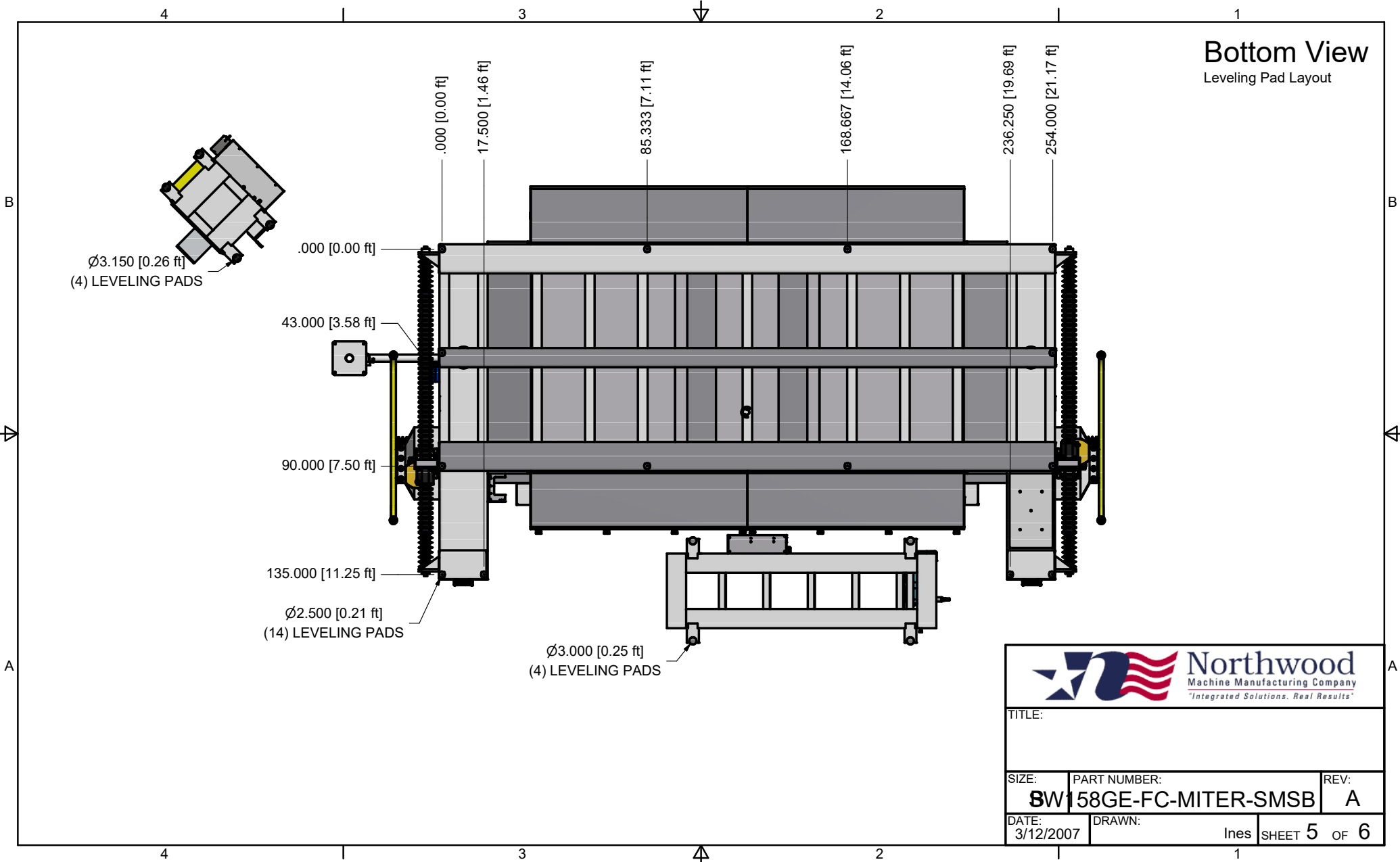

 <b>Northwood</b> Machine Manufacturing Company <i>"Integrated Solutions. Real Results"</i>		
TITLE:		
SIZE:	PART NUMBER:	REV:
	<b>SW158GE-FC-MITER-SMSB</b>	<b>A</b>
DATE:	DRAWN:	Ines SHEET 5 OF 6
3/12/2007		

4

3



2

1

# Front View

Safe Lift Points

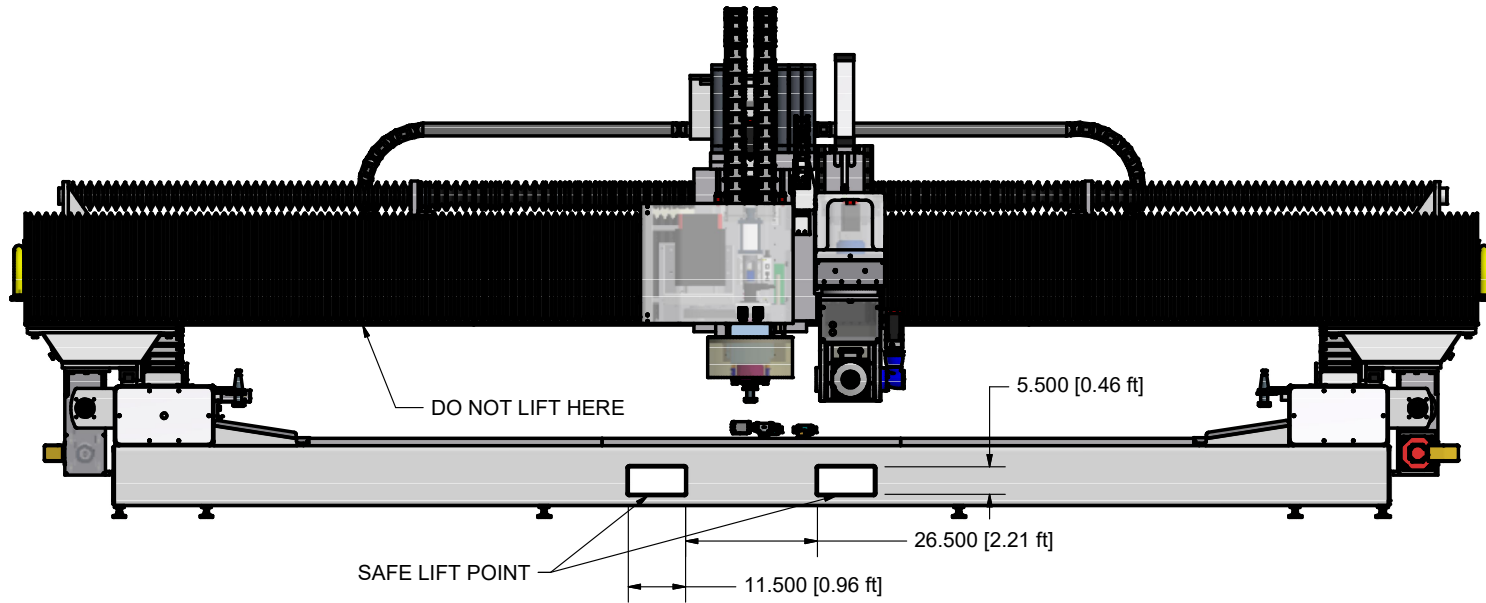

**Northwood**  
Machine Manufacturing Company  
*"Integrated Solutions. Real Results"*

TITLE:		
SIZE:	PART NUMBER:	REV:
	<b>SW158GE-FC-MITER-SMSB</b>	<b>A</b>
DATE:	DRAWN:	Ines SHEET 6 OF 6
3/12/2007		

4

3



2

1